

FREEDOM60[®]

Syringe Infusion System 

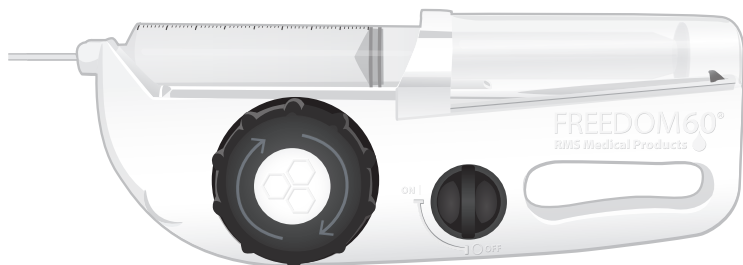

Instructions For Use

Introduction.....	2
Indications for Use.....	2
Caution.....	3
FREEDOM60 [®] Syringe Driver Diagram.....	4
FREEDOM60 [®] Product Line.....	4
Syringes for Use with FREEDOM60 [®]	4
Testing FREEDOM60 [®] Syringe Driver.....	5
Selected Flow Rates vs Time.....	5
Subcutaneous Infusion Instructions.....	6
Intravenous Infusion Instructions.....	8
Troubleshooting.....	11
Care and Maintenance.....	12
FREEDOM60 [®] Flow Profile.....	14
Technical Specifications.....	14
Selected Flow Rate Combinations.....	15
Warranty Information.....	17
Definition of Symbols.....	19

Introduction:

The FREEDOM60[®] Syringe Infusion System is portable and easy to use, requiring no batteries or electricity. There are only two operating knobs and special precision tubing sets are used to control the flow rate.

The FREEDOM60[®] operates at a constant safe pressure of 13.5psi. The constant pressure developed in the FREEDOM60[®] automatically decreases the flow rate if there is an increase in resistance during the delivery. The system will find equilibrium between the increasing resistance and flow rate. It provides constant flow which tends to inhibit clots, and holds full pressure after an infusion is complete to prevent blood or drug backflow. The FREEDOM60[®] also eliminates concerns of a bolus, overflow, overdose or runaway infusion.

Indications for Use:

The Freedom Integrated Syringe Infusion System, which includes the FREEDOM60[®] and FreedomEdge[®] syringe drivers, is indicated for the intravenous or subcutaneous infusion of medications and fluids in the home, hospital, or ambulatory settings when administered according to the approved biologic or drug product labeling. The Freedom System is specifically indicated for the subcutaneous infusion of the following human plasma-derived immunoglobulins when used according to the FDA approved biologic labeling: Hizentra, Immune Globulin Subcutaneous (Human) 20% Liquid (manufactured by CSL Behring); Gammagard Liquid, Immune Globulin Infusion (Human) 10% (manufactured by Takeda); and Cuvitru Immune Globulin Infusion (Human) 20% (manufactured by Takeda). The Freedom System is specifically indicated for the intravenous infusion of the following antibiotics when used according to the FDA approved drug product labeling: meropenem, ertapenem, oxacillin, and tobramycin.

The FREEDOM60[®] Syringe Infusion System is indicated for use with the BD[®] 50 ml syringe (US Reference number 309653).



Caution:

- Use the FREEDOM60® Syringe Infusion System only for the patient for whom the device is prescribed and only for its intended use.
- In order to achieve specific and repeatable flow rate performance with the Freedom Syringe Infusion Systems' unique constant force mechanism, use only Freedom System accessories manufactured by KORU Medical Systems. Directly connecting extension tubing or administration set (without the luer disc) will cause the syringe to eject from the syringe driver and eventually cause internal damage to it. Use of any other flow control accessory may also cause over delivery of fluids or medication to the patient. For use with subcutaneous immune globulin products, use only KORU flow control devices and HlGH-Flo needle sets, as use of generic products may result in unknown flow rates and additional site complications such as pain, swelling and redness.
- Use only recommended BD® 50 ml syringes with the FREEDOM60®.
- Before use, carefully inspect the tubing set package. Do not use the tubing set if the package is opened or damaged.
- Do not re-sterilize tubing sets.
- Overuse of the slide clamp or storing tubing sets with the slide clamp engaged for long periods of time* may damage the tubing and affect the infusion rate.
- The black tab that pushes on the syringe plunger operates under high force. Do not place fingers on the black tab or inside the syringe shield at any time. Do not attempt to interfere with the movement of the black tab at any time.
- Carefully inspect the FREEDOM60® Syringe Driver before use. Discontinue use of a syringe driver that has been damaged, exposed to severe impact, or which has failed to test properly.
- Do not attempt to open the syringe driver housing or remove the syringe shield. Do not operate if the syringe shield has been removed.
- Do not attempt to remove the syringe or disconnect the tubing set without first turning the syringe driver OFF and fully winding the large knob clockwise until the black tab has reached the end of its track.
- The FREEDOM60® Syringe Infusion System does not have an alarm, therefore no alarm will sound if an interruption to flow occurs. There is no display of infusion status. The syringe driver is not suitable for use with medication where delay or under-infusion could result in serious injury.
- Discontinue use of a syringe driver that has been submerged in fluid. If any fluid is allowed to enter the syringe driver, it should be replaced immediately.
- Do not autoclave the FREEDOM60®. It will melt the ABS plastic and damage the syringe driver.
- Federal law (USA) restricts this device to sale by or on the order of a physician.
- Priming and shipping of tubing sets, packaged at temperatures below freezing, is not recommended. This may damage the tubing.
- The FREEDOM60® Syringe Infusion System is not intended for blood transfusions.

*Generally greater than 2 hours.

FREEDOM60[®] Syringe Driver Diagram:

FREEDOM60[®]
Syringe Infusion System

Patent No. D398,053

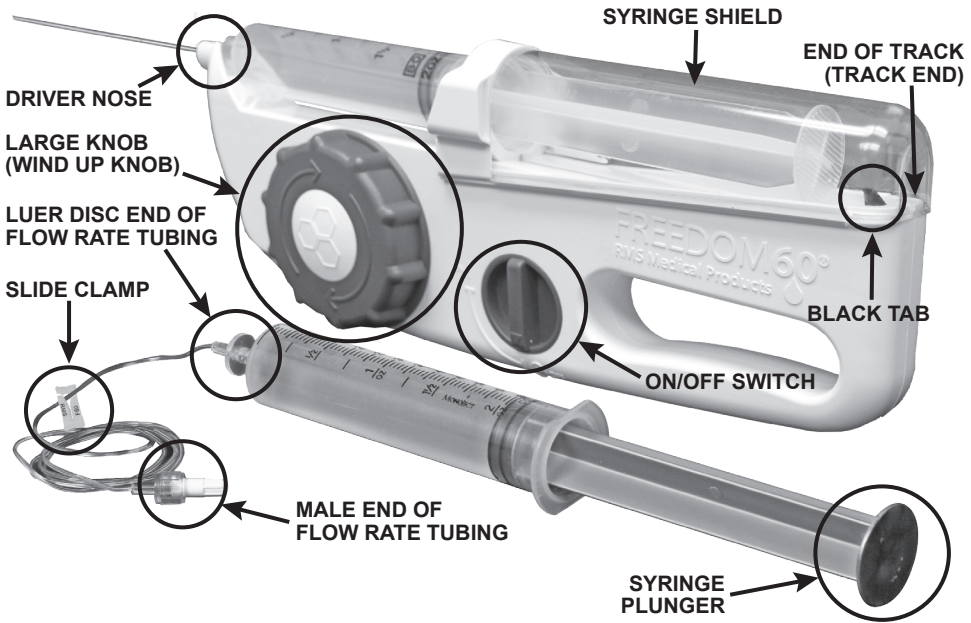

FREEDOM60[®] Product Line:

Each FREEDOM60[®] Syringe Infusion System includes a travel pouch and user manual.

Product	Part #
FREEDOM60 [®] Syringe Driver	F10050
Replacement Travel Pouch - black	F10090
Zebra Print Travel Pouch - pattern	F10080

Syringes for use with the FREEDOM60[®]:

- Becton Dickinson & Co. BD[®] Luer-Lok[®] 50 ml (US Reference #309653; EU Reference #300865)

For Smaller Volume Infusions:

The FREEDOM60[®] is designed to accommodate BD[®] 50 ml syringes. For smaller volumes, the FreedomEdge[®] accommodates both 20 ml and 30 ml syringes.

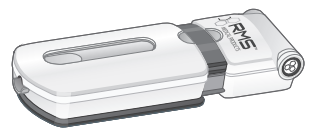

Part #: F10020

Testing the FREEDOM60® Syringe Driver:

1. Examine the inside of the syringe shield and ensure it is free of debris or contamination.
2. Make sure that the syringe driver's on/off switch is in the OFF position and that the black tab within the syringe shield is at the end of its track. If the black tab is not at the end of its track, fully wind the large knob clockwise.
3. Turn the syringe driver ON (-) and watch that the tab moves smoothly along the full length of its track; listen for the following sounds:
 - a 'click' as the driver is turned ON (-)
 - a 'whirring' sound as the black tab moves forward
 - a 'click' as the tab reaches the end of its travel
4. Test to make sure the syringe tension tab (the one-inch long tab located at the entry of the syringe shield) operates freely by adjusting it up and down with your finger.

Selected Flow Rates vs Time:

Note: For assistance in determining which flow rate tubing set to use, please contact KORU Medical Systems at 800-624-9600.

Flow Rate vs Time Chart

Syringe Volume	1ml/hr	2ml/hr	30ml/hr	45ml/hr	60ml/hr	120ml/hr
5	5 hrs.	2 hrs. 30 min.	10 min.	6 min. 42 sec.	5 min.	2 min. 30 sec.
10	10 hrs.	5 hrs.	20 min.	13 min. 18 sec.	10 min.	5 min.
15	15 hrs.	7 hrs. 30 min.	30 min.	20 min.	15 min.	7 min. 30 sec.
20	20 hrs.	10 hrs.	40 min.	26 min. 42 sec.	20 min.	10 min.
25	25 hrs.	12 hrs. 30 min.	50 min.	33 min. 18 sec.	25 min.	12 min. 30 sec.
30	30 hrs.	15 hrs.	60 min.	40 min.	30 min.	15 min.
35	35 hrs.	17 hrs. 30 min.	70 min.	46 min. 42 sec.	35 min.	17 min. 30 sec.
40	40 hrs.	20 hrs.	80 min.	53 min. 18 sec.	40 min.	20 min.
45	45 hrs.	22 hrs. 30 min.	90 min.	60 min.	45 min.	22 min. 30 sec.
50	50 hrs.	25 hrs.	100 min.	66 min. 42 sec.	50 min.	25 min.
55	55 hrs.	27 hrs. 30 min.	110 min.	73 min. 18 sec.	55 min.	27 min. 30 sec.
60	60 hrs.	30 hrs.	120 min.	80 min.	60 min.	30 min.

For Subcutaneous Infusions, Follow These Instructions:

Prepare the FREEDOM60® Syringe Driver:

1 Wash Hands

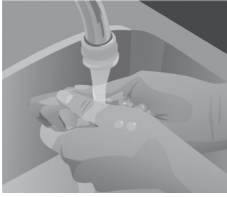

Gather supplies. Wash your hands thoroughly and, if required, put on disposable gloves.

2 Fill Syringe

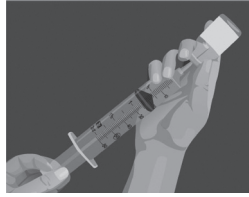

Be sure the product is at room temperature before you begin filling the BD® 50 ml syringe with your required dose. Refer to the manufacturer's instructions or ask your provider for more detailed filling instructions.

3 Verify Tubing & Needles

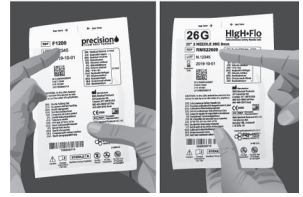

Verify that you are using the correct tubing and needle sets recommended by your health-care provider and prescribed by your doctor.

4 Attach Tubing

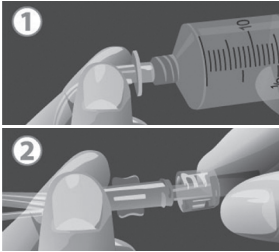

1. Remove sterile cap from the luer disc end of the Precision tubing set and connect to syringe.
2. Remove sterile caps from opposite end of tubing set and High-Flo needle set and connect, using care not to contaminate ends.

5 Check Black Tab

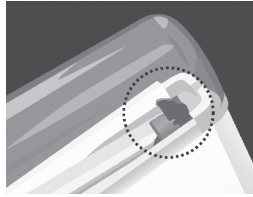

Make sure the syringe driver is off and the black tab inside the clear syringe shield is at the end of its track. If the black tab is not at the end of its track, wind the large knob clockwise.

6 Insert Syringe

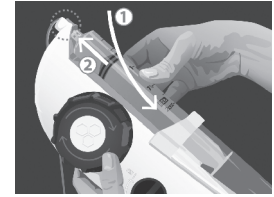

With syringe gradations facing up:
1. load the syringe and its tubing into the syringe driver.
2. Make sure the luer disc is fully seated in the driver's nose.

Note: You will never need to use force to load or remove a syringe. If you're having trouble, stop and make sure the black tab is at the end of its track.

Prime Tubing:

7 Turn ON

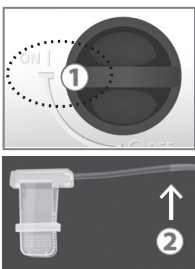

1. Turn the syringe driver's ON/OFF switch to the ON position (fill) the tubing.
2. Try to stop the flow about 2" short of the needle(s).

8 Turn OFF



To stop flow to needle(s), turn the syringe driver's ON/OFF switch to the OFF position.

9 Wind Back



Wind the large knob clockwise until the black tab is clearly not touching the syringe. This will release pressure on the plunger and stop the flow.

Insert Needles/Check for Blood Return:

10 Prepare Sites



Select your site(s), cleanse with alcohol and let dry. Carefully remove shield from the needle tip, with care not to touch the needle.

11 Insert



Pinch the skin and insert each needle into the subcutaneous tissue at a 90° angle.

12 Secure



Secure needle(s) with adhesive dressing.

13 Pull Back



Remove the syringe from the syringe driver. Check for blood return by gently pulling back on the syringe plunger.

14 Watch

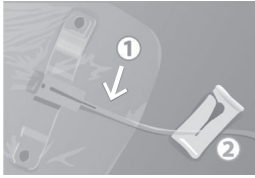

1. Watch to make sure no red/pink appears in tubing near your sites.
2. If blood return exists, clamp the flow to that site and call your healthcare provider to determine if the dose can be run using the remaining sites. If so, continue. If not, remove all needles, attach a new needle set and start again from step 6 of Prepare section.

Begin Infusion:

15 Insert Syringe



With syringe gradations facing up, insert the syringe back into the syringe driver.

16 Turn ON

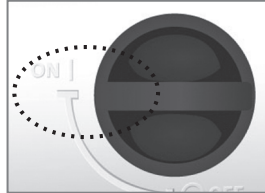

Turn the syringe driver's ON/OFF switch to the ON position.

After Infusion is Complete:

17 Turn OFF



Once infusion is complete, turn the syringe driver's ON/OFF switch to the OFF position.

18 Remove Needle(s)

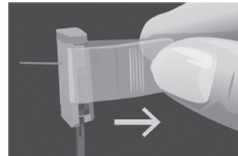

Hold needle in place and peel back any adhesive/dressing around it. Remove needle(s) in a straight motion, opposite the direction you inserted it.

19 Wind Back

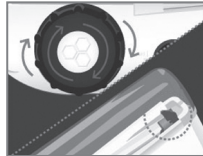

Wind the large knob until the black tab is at the end of its track.

20 Remove Syringe



1. Pull syringe away from the syringe driver's nose and, 2. remove syringe from the syringe driver. Cleanse each site and cover with a bandage. Discard all sharps and biologics as required.

For Intravenous Infusions, Follow These Instructions:

Prepare the FREEDOM60® Syringe Driver:

1 Wash Hands

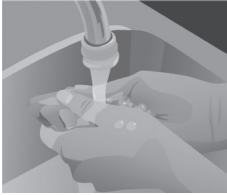

Gather supplies. Wash your hands thoroughly and, if required, put on disposable gloves.

2 Wind Back

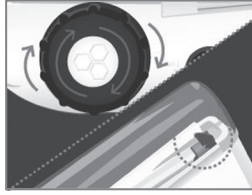

Make sure that the ON/OFF switch is in the OFF position and that the black tab is at the end of its track. If tab is not at the end of its track, wind knob clockwise.

3 Attach Tubing

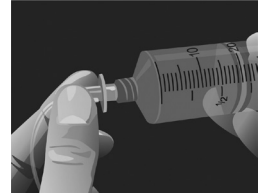

Remove sterile cap from luer disc end of the Precision tubing set and connect to syringe. Check the F-number on the clamp to make sure you have the correct set.

4 Insert Syringe



With syringe gradations facing up:

1. load the syringe and its tubing into the syringe driver.
2. Make sure the luer disc is fully seated in the driver's nose.

Note: You will never need to use force to load or remove a syringe. If you're having trouble, stop and make sure the black tab is at the end of its track

Prime Tubing:

5 Turn ON

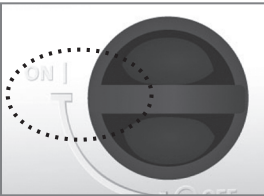

Turn the syringe driver's ON/OFF switch to the ON position.

6 Loosen Cap



Loosen the cap on the Precision tubing set.

Watch for Drip 7 & Tighten Cap



When medication starts to drip, tighten the cap on the tubing.

8 Turn OFF



Turn the syringe driver's ON/OFF switch to the OFF position.

9 Wind Back

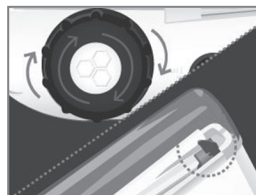

Wind the large knob until the black tab is at the end of its track.

Flush: *Always follow your provider's protocol.*

10 Clean Valve



Follow your providers instructions to disinfect your valve using an alcohol pad or disinfection cap. Avoid touching disinfected opening of the valve.

11 Attach Flush

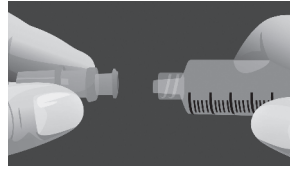

Connect the syringe directly into the valve and turn clockwise.

12 Open Clamp



Open the clamp on the access catheter and/or extension set.

13 Flush

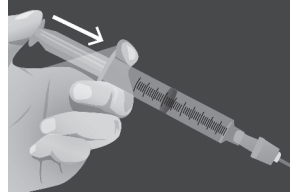

Flush with a gentle push and pause method.

Infuse Dose:

14 Connect

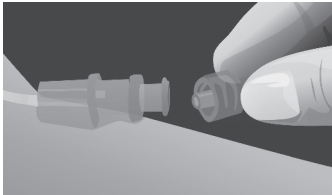

Uncap the Precision tubing set. Turning clockwise, connect the Precision tubing to the valve.

15 Turn ON

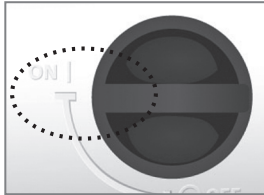

Check that all clamps are open. Turn the syringe driver's ON/OFF switch to the ON position to begin the infusion.

16 Check Infusion



Periodically check that the syringe driver is working by seeing that the syringe plunger is moving.

After Infusion is Complete:
(When syringe is completely empty)

17 Clamp

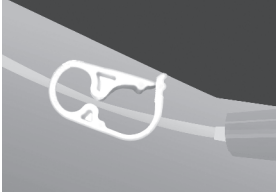

Clamp the access catheter and/or extension set.

18 Turn OFF



Turn the syringe driver's ON/OFF switch to the OFF position.

19 Detach Tubing

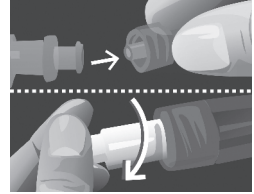

Disconnect the Precision tubing set and attach sterile protection cap to set.

20 Flush & Clamp

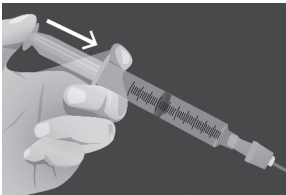

Repeat Flush steps, and if instructed by nurse - flush with Heparin. Clamp when done.

21 Wind Back

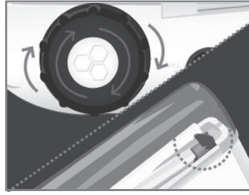

Wind the large knob until the black tab is at the end of its track.

22 Remove Syringe

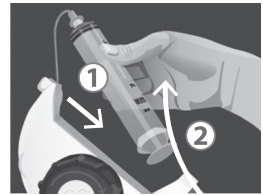

1. Pull syringe away from the syringe driver's nose and, 2. remove syringe from the syringe driver.

Troubleshooting:

If the suggestions in this section do not solve your problem, or if problems persist, discontinue use and consult your medical provider.

Syringe will not load or remove from syringe driver:

- You will never need to use force to load or remove a syringe.
- Make sure the syringe driver is in the OFF position and that the black tab is at the end of its track. If the black tab is not at the end of its track, fully wind the large knob clockwise and try again.
- Verify that you are using the proper BD® 50 ml syringe.

Syringe will not stay inside in the syringe driver:

- Make sure you are using the proprietary Precision Flow Rate Tubing™ sets with the luer disc.
- Make sure the luer disc end of the tubing has been connected to a BD® 50 ml syringe and that it is seated properly in the nose of the syringe driver.

No flow:

- Assure that the syringe driver is in the ON (–) position.
- Make sure the slide clamp is unclamped, and has not been used for an extensive period of time. If the slide clamp is overused it can damage the tubing.
- Test the tubing: While the syringe driver is in the ON (–) position, use sterile procedures to disconnect the rate controlled tubing set from the indwelling needle or catheter; check for medication drip. If medication does not drip, replace the tubing as it may be blocked or damaged. If medication does drip from the rate controlled tubing, then it's most likely a problem with the indwelling needle, catheter, or any fluid path accessories such as a needle-free adapter.

Slow flow:

- If a slide clamp is used for an extensive period of time, it can damage the tubing and affect the flow rate. Try using another tubing set and measure the flow. For 60ml/hr tubing, the syringe plunger should move 10ml in 10 minutes (1ml/min). For 120ml/hr tubing, the plunger should move 10ml in 5 minutes (2ml/min).

Flow may continue even when the syringe driver is turned OFF:

- This is a normal function of the driver. The syringe driver is designed to maintain pressure during and after the infusion to prevent blood/drug backflow.
- To stop the flow turn the driver OFF and wind the large knob clockwise so the black tab moves away from the syringe. This will release pressure on the plunger.
- You can also use the slide clamp. We recommend using the slide clamp to immediately stop the flow only in the case of an emergency. Overuse can damage the tubing.

Medication (5ml or less) left in the syringe:

- Verify that you are using the proper BD® brand 50 ml syringe.

Care and Maintenance:

The FREEDOM60® does not require any preventative maintenance. The FREEDOM60® works as a system, which means the tubing determines the flow rate, not the syringe driver; therefore our syringe driver needs no calibration. If you choose the correct tubing set the proper flow rate will be achieved.

Cleaning:

Clean only those areas that are exposed and external. No attempt should be made to clean any part of the syringe driver that is not easily accessible. Discontinue use of a syringe driver that has been internally exposed to or immersed in fluid. Wipe the surface with warm water and detergent or use any surface disinfectant compatible with plastic, such as household bleach or hydrogen peroxide. Avoid the use of alcohol or alcohol containing compounds, as these tend to make ABS plastic brittle. Wipe again with clean water to rinse.

Storage:

The FREEDOM60® syringe driver is recommended to be stored in a cool, dry place and packaged tubing sets at room temperature (approximately 16-30°C or 61-86°F).

Testing Flow Accuracy (if required by your local protocol):

1. Fill a new syringe with 50 ml of sterile water
2. Remove all air from the syringe
3. Attach a sterile Precision Flow Rate Tubing™ set to the syringe
4. Remove all air from the tubing set
5. Load the syringe into the driver and turn it ON (-)
6. Monitor the syringe readings and elapsed time to derive an approximate flow rate

7. Compare your test results to the range of test rates listed in the table below:

Tubing F#	Bench-Rated Flow Rate	Test Range
F60	72ml/hr	60-84ml/hr
F120	134 ml/hr	115-153ml/hr

7a. **Bench-Rated Flow Rate:** The FREEDOM60[®] syringe driver design accounts for the effects of standard clinical conditions on flow rate performance. Under bench test conditions, a 60ml/hr labeled tubing set is designed to generate a nominal infusion rate of 72ml/hr. A 120ml/hr labeled tubing set will generate a nominal bench test rate of 134ml/hr. The FREEDOM60[®] generates nominal bench test rates higher than the labeled rate accounting for the following standardized application criteria that affects actual delivery rates under normal clinical circumstances.

	F60 Tubing	F120 Tubing
Bench Test Rate	72ml/hr	134ml/hr
Less Clinical Effects		
Catheter Gauge (20G PICC)	-7ml/hr	-8ml/hr
Fluid Viscosity	-2ml/hr	-3ml/hr
Venous Pressure	-3ml/hr	-3ml/hr
Label Flow Rate	60ml/hr	120ml/hr

7b. **Test Range:** To assure consistent test results, keep syringe driver and tubing at the same approximate horizontal plane and monitor flow for a minimum of 20 minutes. The FREEDOM60[®] system is factory rated to deliver infusions under strict test conditions over a large number of drivers tested within 7% of nominal with a 95% statistical confidence interval. Under varying bench test and fluid conditions this range can be expected to vary approximately 15% of nominal. For more accurate monitoring, use a stopwatch and finely graduated burette. FREEDOM60[®] syringe driver testing is based on ANSI/AAMI National Standard, ID 26-1992, Infusion Devices, August 24, 1992.

If test results in the range indicated cannot be approximated under bench testing conditions, factory refurbishment and full certification testing is available from the manufacturer.

References:

1. Stuhmeier, Mainzer B. MD; Aspects of pressure build-up in the use of electronic infusion devices. II. Need for a pressure limit. *Anasth Intensivther Notfallmed* (1987 Aug.) 22(4): 185-190.
2. *Anasth Intensivther Notfallmed* (1987 Aug.) 22(4): 181-184. ANSI/AAMI National Standard, ID 26-1992, Infusion Devices, August 24, 1992.

FREEDOM60® Flow Profile:

The FREEDOM60® flow profile shows that the flow rate is consistent throughout the delivery of medication.

FREEDOM60® Flow Rate vs. Time

Fluid: H₂O • Fluid Volume: 60ml • Tubing Measured: F120 – 120ml/hr

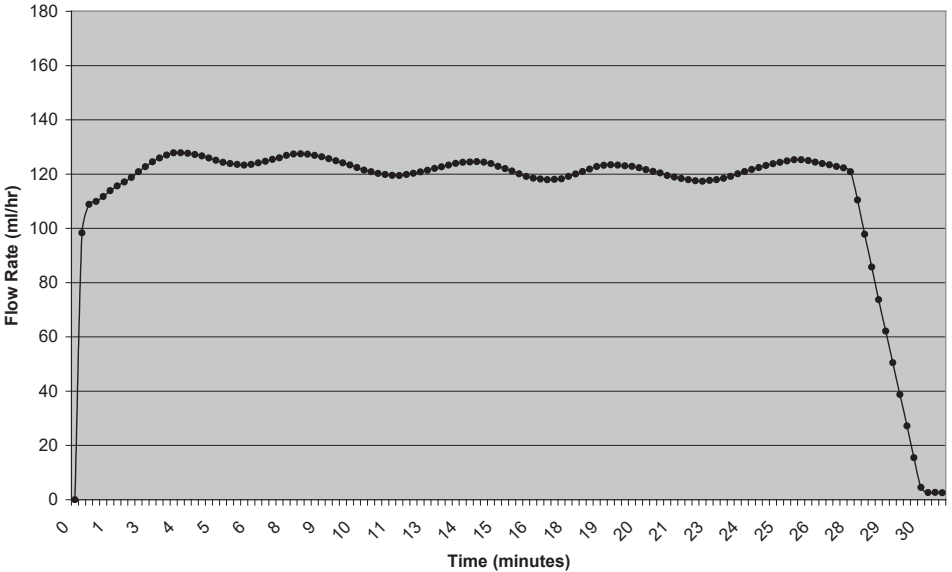

Technical Specifications:

System

Reservoir volume:	60ml (maximum)
Residual volume:	<0.4ml
Flow rate accuracy:	± 8%*
Operating pressure:	15psi (peak) 13.5psi (nominal)
Height sensitivity:	± 3% per 12" (30cm)
Constant force mechanism:	± 3%

*Flow rate data recorded at 22°C using 60ml of 0.9% NS. An overall accuracy of ±7% is expected at these values. At higher temperatures, which results in a decrease in viscosity, a higher flow rate is anticipated to occur. The flow rate variation due to changes in temperature is approximately linear and would vary from -20% at 14°C to +20% at 30°C. Fluids considerably more viscous than 0.9% NS are expected to slow the flow rate and consequently may result in longer infusion times. More viscous fluids may be tested before patient use by following the bench test procedures described in this manual.

Syringe Driver

Weight: 14oz (0.4kg)
 Length: 12" (304mm)
 Width: 4.5" (114mm)
 Height: 1.6" (41mm)

Precision Flow Rate Tubing™

Length: 6" to 72" (152mm-1829mm)

Precision Flow Rate Tubing™ / Residual Volume (ml)

Part #	Res. Vol.	Part #	Res. Vol.
F0.5	0.09	F60	0.14
F1	0.08	F120	0.16
F2	0.10	F180	0.13
F3	0.09	F275	0.11
F3.8	0.09	F420	0.10
F5	0.08	F500	0.09
F8	0.08	F600	0.09
F10	0.14	F900	0.08
F15	0.11	F1200	0.13
F30	0.13	F2400	0.15
F45	0.11		

precision
 FLOW RATE TUBING™

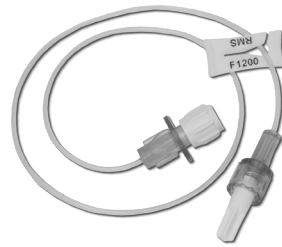

Select Combinations of Flow Rates and Needles Sets for Use with Hizentra, Cuvitra, and Gammagard Liquid

(Note that the following tables are only for the subcutaneous use of the immunoglobulin listed.)

Hizentra – with FREEDOM60® or FreedomEdge® with 20ml syringe							
Drug volume (ml)	Flow Tube	High Flo Set*	Flow Rate Total (ml/hr)	Flow rate/site (ml/hr)	Vol/site (ml)	Time	NOTES:
10	F120	RMS 1-2609	8.2	8.2	10	1:12	Suggested start Peds
10	F180	RMS 1-2609	10.5	10.5	10	0:57	Suggested start Peds
20	F275	RMS 2-2609	17.1	8.5	10	1:10	Suggested start Peds
20	F600	RMS 2-2609	29.6	14.8	10	0:40	Suggested start Peds
40	F600	RMS 3-2609	33.9	11.3	13.3	1:10	Suggested start Adult
40	F900	RMS 3-2609	44.3	14.8	13.3	0:54	Suggested start Adult
60	F900	RMS 4-2609	49	12.3	15	1:13	Suggested start Adult
50	F2400	RMS 3-2609	72.2	24.1	16.67	0:41	6 th Infusion of biologic and beyond
100	F2400	RMS 4-2609	85.5	21.4	25	1:10	6 th Infusion of biologic and beyond (NEEDS TWO SYRINGES)
Hizentra - with FreedomEdge® with 30ml syringe							
20	F600	RMS 2-2609	22.5	11.2	10	0:53	Suggested start Peds
30	F900	RMS 2-2609	28.3	14.2	15	1:03	Suggested start Adult
30	F2400	RMS 2-2609	41.9	20.9	15	0:42	6 th Infusion of biologic and beyond

Note 1. Based on combining elements as written in Theory and Measurement of Fluid Flow Rates in the Freedom system. Other combinations available per request.

Note 2. 24 G needles are not needed for performance up to 24.08 ml/hr for Hizentra.

(Note that the following tables are only for the subcutaneous use of the immunoglobulin listed.)

***Note:** HlgH-Flo needle sets: First number references the number of needles, the next two numbers reference the needle gauge, and the last two numbers reference the needle length in millimeters

Cuvitru – with FREEDOM60® or FreedomEdge® with 20ml syringe							
Drug volume (ml)	Flow Tube	High Flo Set*	Flow Rate Total (ml/hr)	Flow rate/site (ml/hr)	Vol/site (ml)	Time	NOTES:
10	F275	RMS 1-2609	12.1	12.1	10	0:49	1 st Two Infusions patients under 40kg
20	F275	RMS 1-2609	12.1	12.1	20	1:39	1 st Two Infusions patients under 40kg
20	F600	RMS 2-2609	25.7	12.8	10	0:47	1 st Two Infusions patients under 40kg
50	F600	RMS 2-2609	25.7	12.8	25	1:57	1 st Two Infusions patients over 40kg
60	F1200	RMS 2-2609	37.1	18.6	30	1:37	Subsequent Infusions
60	F2400	RMS 2-2409**	110.5	55.4	30	0:32	Subsequent Infusions
60	F1200	RMS 1-2409**	55.3	55.3	60	1:05	Subsequent Infusions
100	F2400	RMS 4-2409**	132.8	33.2	25	0:45	Subsequent Infusions
Cuvitru – with FreedomEdge® with 30ml ml syringe							
20	F500	RMS 1-2609	12.9	12.9	20	1:32	1 st Two Infusions patients under 40kg
30	F900	RMS 2-2609	24.6	12.3	15	1:13	1 st Two Infusions patients over 40kg
30	F2400	RMS 1-2609	21.2	21.2	30	1:24	Maintenance Infusions
30	F1200	RMS 1-2409**	42.1	42.1	30	0:42	Maintenance Infusions

**Indicates 24 gauge needle was used.

Gammagard Liquid – with FREEDOM60® or FreedomEdge® with 20ml syringe							
Drug volume (ml)	Flow Tube	High Flo Set*	Flow Rate Total (ml/hr)	Flow rate/site (ml/hr)	Vol/site (ml)	Time	NOTES:
20	F45	RMS 1-2609	14.2	14.2	20	1:24	Patients under 40kg (Initial)
60	F120	RMS 2-2609	39.8	19.9	30	1:30	Patients over 40kg (Initial)
100	F420	RMS 4-2609	119.1	29.8	25	0:50	Patients over 40kg (maintenance infusions)
Gammagard Liquid – with FreedomEdge® with 30ml syringe							
20	F120	RMS 2-2609	30	15	10	0:40	Patients under 40kg (Initial)
30	F180	RMS 2-2609	39.8	19.9	15	0:45	Patients over 40kg (Initial)
30	F120	RMS 1-2609	27	27	30	1:06	Patients over 40kg (Maintenance)

Warranty Information:

Limited Warranty: KORU Medical Systems/Repro Med Systems, Inc. (“Manufacturer”) warrants the syringe driver to be free from defects in materials and workmanship under normal use. Warranty is limited to Original Purchaser and covers the FREEDOM60® for a period of two years from the purchase date. This warranty is not valid for any damage caused by the use of non-KORU products. The “Original Purchaser” is the person purchasing the syringe driver from the Manufacturer or Manufacturer’s Representative. Warranty does not extend to subsequent purchasers. Subject to the conditions of and upon compliance with the procedures set forth in this limited warranty, the Manufacturer will repair or replace, at its option, any syringe driver, or part thereof, which has been actually received by the Manufacturer or Manufacturer’s Representative within the two-year warranty period, and which examination discloses, to the Manufacturer’s satisfaction, that the product is defective. Replacement product and parts are warranted only for the remaining portion of the original two-year warranty period.

















KORU tests the FREEDOM60® using KORU accessories to ensure that the FREEDOM60® operates in accordance with published specification standards. If non-KORU accessories are used in conjunction with the FREEDOM60®, KORU does not represent that the FREEDOM60® will operate in accordance with published specification standards. The FREEDOM60® warranty does not cover third-party products or accessories.

The following conditions, procedures, and limitations apply to the Manufacturer's obligations under this warranty:

- **Parties Covered by this Warranty:** This warranty extends only to the Original Purchaser of the infusion syringe driver. This warranty does not extend to subsequent purchasers.
- **Warranty Performance Procedure:** Notice of the defect must be made in writing to Customer Support Department, KORU Medical Systems/Repro Med Systems, Inc., 24 Carpenter Road, Chester, NY 10918, USA. Notice to KORU Medical Systems/Repro Med Systems, Inc. must include the model and serial number, date of purchase, and description of the defect in sufficient detail to facilitate repairs. Authorization must be obtained by the Original Purchaser from the Manufacturer or Manufacturer's Representative prior to returning the product to the Manufacturer. The defective syringe driver must be properly packaged and returned to the Manufacturer, postage-prepaid. Any loss or damage during shipment is at the risk of the Original Purchaser.
- **Conditions of Warranty:** This warranty does not apply to any product, or part thereof, which has been repaired or altered outside of the Manufacturer's facility in a way so as, in Manufacturer's judgment, to affect its stability or reliability, or which has been subjected to misuse, negligence or accident.
- **Limitations and Exclusions:** Repair or replacement of a syringe driver or component part is the EXCLUSIVE remedy offered by the Manufacturer. The following exclusions and limitations shall apply:
 - No agent, representative, or employee of the Manufacturer has authority to bind the Manufacturer to any representation or warranty, expressed or implied, or to change this limited warranty in any way.
 - THIS LIMITED WARRANTY IS IN LIEU OF ALL OTHER WARRANTIES, EXPRESS OR IMPLIED, INCLUDING, BUT NOT LIMITED TO, WARRANTIES OF MERCHANTABILITY AND FITNESS FOR A PARTICULAR PURPOSE. THERE ARE NO WARRANTIES THAT EXTEND BEYOND THE DESCRIPTION ON THE FACE HEREOF.
 - Manufacturer's liability under this Limited Warranty Agreement shall not extend to special, indirect, or consequential damages.
 - The syringe driver can only be used under the supervision of medical personnel whose skill and judgment determine the suitability of the syringe driver for a particular medical treatment.
 - All recommendations, information, and descriptive literature supplied by the Manufacturer or its agents are believed to be accurate and reliable, but do not constitute warranties.

This warranty and the rights and obligations hereunder, shall be construed under and governed by the laws of the State of New York, USA.

Definition of symbols:

	On		Quantity
	Off		Catalog number
	Caution		Do not reuse
	Consult instructions for use		Serial number
	Authorized representative in the European Community		Sterilized using irradiation
	Use by YYYY-MM-DD or YYYY-MM		European Conformity
	Batch code		Do Not Use if Package is Damaged
	Manufacturer		Prescription Only



KORU Medical Systems 800-624-9600 toll free
24 Carpenter Road 845-469-2042 local
Chester, NY 10918 USA korumedical.com



The FREEDOM60® and FreedomEdge® Syringe Infusion Systems, Precision Flow Rate Tubing™, HlgH-Flo Subcutaneous Safety Needle Sets™ are registered trademarks of KORU Medical Systems and are compliant with Medical Device Directive 93/42/EEC. KORU Medical Systems is ISO 13485 certified. ©2019 KORU Medical Systems; All Rights Reserved.